



CORD REEL AND WORK LIGHT MANUFACTURE

线盘工作灯专业生产、供应商

- ◆ 获得国家多项专利技术
Obtained national patents
- ◆ 产品通过多家权威质量检测机构认证
Products certified by many authoritative quality inspection institution
- ◆ 杭州市高新技术企业
The high-tech enterprises in Hangzhou City
- ◆ 坚持不断创新经营理念
Adhere to the business philosophy of continuous innovation
- ◆ 坚持高标准质量要求
Adhere to high standards of quality requirements



地址：浙江省建德市梅城镇城南工业园区南洋路292号

电话：0571-64138090 58313053

传真：0571-64147069

邮箱：admin@benewtools.com

网址：www.benewtools.com

Add: No.292 Nanyang Road, Chengnan Industrial Park, Meicheng, Jiande, Zhejiang, China

Phone: 86-571-64138090 58313053

Fax: 86-571-64147069

E-mail: admin@benewtools.com

Http://www.benewtools.com

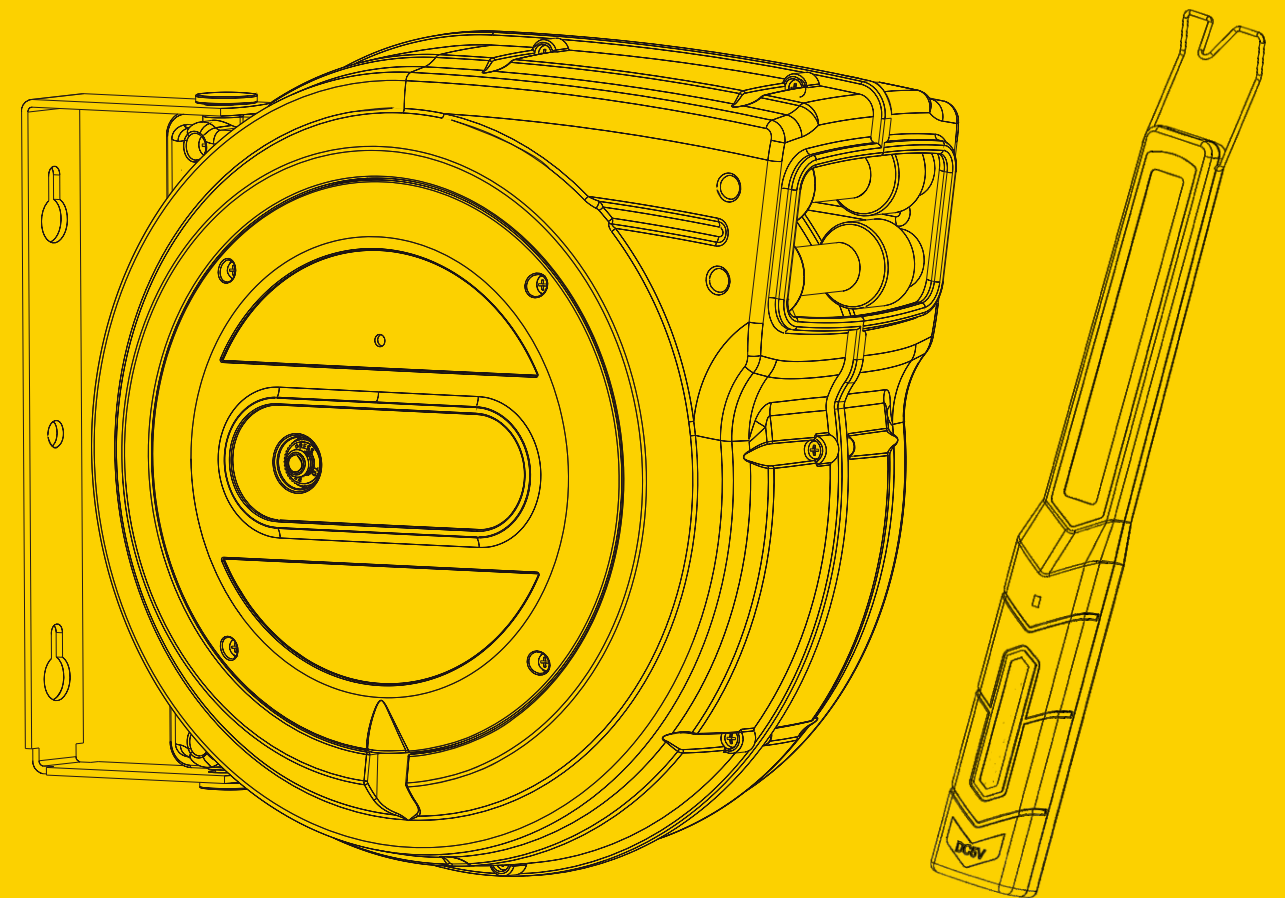

建德市正新工具制造有限公司

ZHEJIANG JIANDE ZHENGXIN MANUFACTURING TOOLS CO.,LTD.

JIANDE ZHENGXIN, Located in Meicheng Town, Jiande, Hangzhou City. Was founded in 2004, main product cover various auto inspection tools, include Power cable reels, Air hose reels, Working lights and so on. 95% of our products was sold to EU and USA market.

"Working sincere, intentions, carefully, and innovation" is the mission that we insisted on. In order to keep strong support for our customer, we established the completed mechanism and electric design team, also research team. Invest R&D team devoted in new product development and current items innovation, and also improve the tools according to customer request. We support the OEM and ODM service as well. We have the advanced production and inspection equipment for the reels and work lights. Establish the completed production and quality control system in our manufacture process.

Quality is the life of company, our products pass the EU and USA request like CE, EMC, UL, CUL ROHS, PAHS, REACH and so on. At same time, we have lots of patent for our products. And we are entitled "Hangzhou High technology Enterprise"



Patent and Certificate





ZD70



ZD150



ZD170



ZD200



ZD250



Retractable Extension Cord Reels

Product Description

- Heavy duty industrial cable reel with spring load
- High quality engineer PP housing
- Wall bracket 180 degree swivel
- Over current or temp.protector
- Pull the power cords and stop any location as you wanted, each stop was around 50cm



Certificates (All model)



ZD70

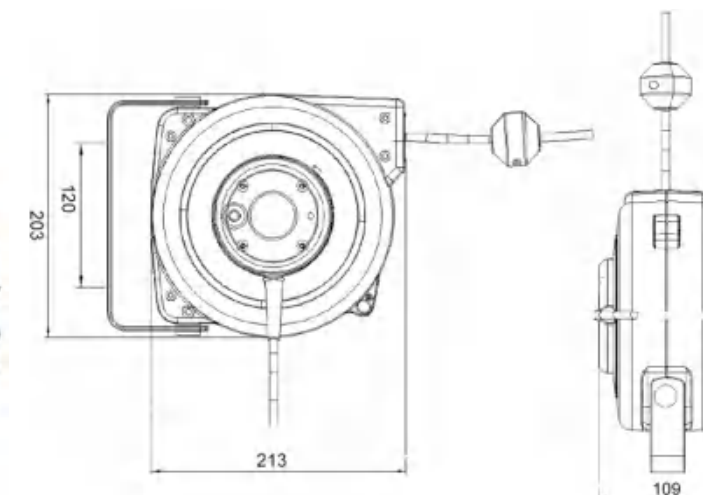

VOLTAGE	LENGTH	WIRE SPEC.	WIRE DIAMETER	Wound	Unwound	TEMP. PROTECT	CURRENT PROTECT	MASTER CARTON	WEIGHT
230V/50HZ	<input type="checkbox"/> 5+1M <input type="checkbox"/> 7+1M	<input type="checkbox"/> H05VV-F <input type="checkbox"/> H07RN-F	3G1.5mm ²	1000W	2300W	56°±5°	NA	L: 58.5cm W:24.5cm H:31.5cm (4 PCS)	2.4 KGS
125V/60HZ	<input type="checkbox"/> 25+4.5FT	<input type="checkbox"/> SJT <input type="checkbox"/> SJTW <input type="checkbox"/> SJTOW	16AWG/3C	1000W	1250W	NA	10A		2.4 KGS

ZD150

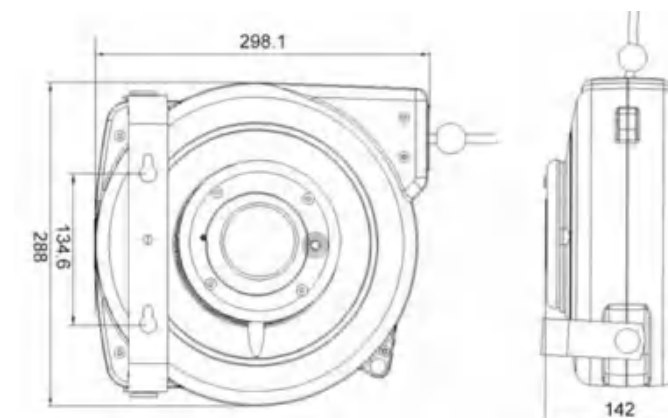

VOLTAGE	LENGTH	WIRE SPEC.	WIRE DIAMETER	Wound	Unwound	TEMP. PROTECT	CURRENT PROTECT	MASTER CARTON	WEIGHT
230V/50HZ	<input type="checkbox"/> 15+1M	<input type="checkbox"/> H05VV-F	<input type="checkbox"/> 3G1.5mm ²	1000W	2300W	56°±5°	NA	L: 36.0cm W:31.5cm H:33.5cm (2 PCS)	6 KGS
	<input type="checkbox"/> 10+1M	<input type="checkbox"/> H07RN-F	<input type="checkbox"/> 3G2.5mm ²	1600W	3200W	56°±5°	NA		6 KGS
125V/60HZ	<input type="checkbox"/> 45+4.5FT	<input type="checkbox"/> SJT	<input type="checkbox"/> 12AWG/3C	1000W	1875W	NA	15A		6 KGS
	<input type="checkbox"/> 50+4.5FT	<input type="checkbox"/> SJTW	<input type="checkbox"/> 14AWG/3C	1000W	1625W	NA	13A		6 KGS
		<input type="checkbox"/> SJTOW	<input type="checkbox"/> 16AWG/3C	1000W	1250W	NA	10A		6 KGS

ZD170

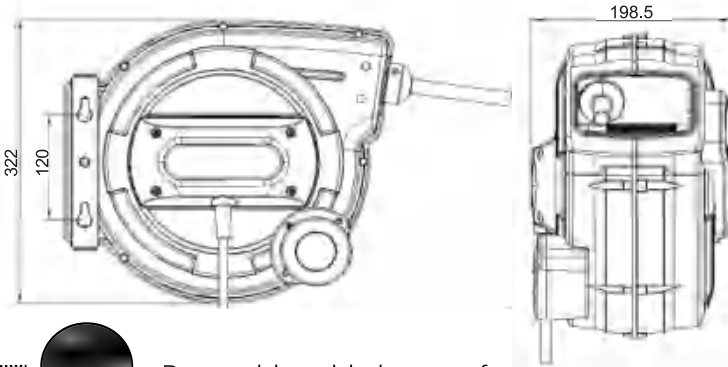

- Retractable cable lay-out function
- 3P+N+ CEE Connector optional
- Slow-down device optional

VOLTAGE	LENGTH	WIRE SPEC.	WIRE DIAMETER	Wound	Unwound	TEMP. PROTECT	CURRENT PROTECT	MASTER CARTON	WEIGHT
230V/50HZ	□ 18+1M	□ H05VV-F	□ 3G1.5mm ²	1000W	2300W	56°±5°	NA	L:37.5cm W:34.0cm H:21.5cm (1PC)	7 KGS
	□ 10+1M	□ H07RN-F	□ 3G2.5mm ²	1600W	3200W	56°±5°	NA		7 KGS
125V/60HZ	□ 60+4.5FT	□ SJT	□ 12AWG/3C	1000W	1875W	NA	15A		7 KGS
		□ SJTW	□ 14AWG/3C	1000W	1625W	NA	13A		7 KGS
		□ SJTOW	□ 16AWG/3C	1000W	1250W	NA	10A	7 KGS	

ZD200

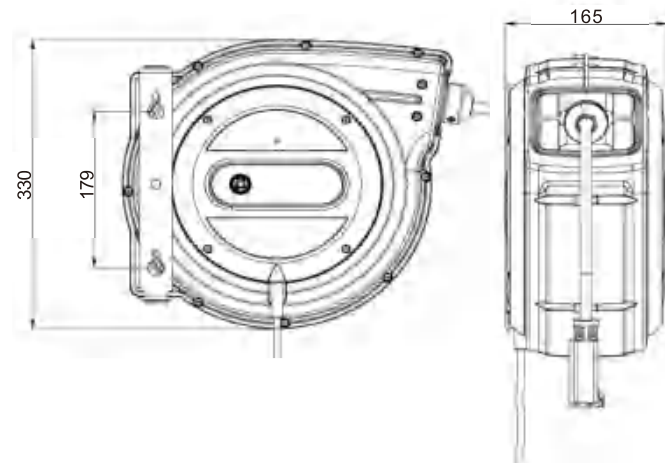

VOLTAGE	LENGTH	WIRE SPEC.	WIRE DIAMETER	Wound	Unwound	TEMP. PROTECT	CURRENT PROTECT	MASTER CARTON	WEIGHT
230V/50HZ	□ 25+1M	□ H05VV-F	□ 3G1.5mm ²	1000W	2300W	56°±5°	NA	L: 39.0cm W: 18.0cm H: 35.5cm (1 PCS)	10 KGS
	□ 20+1M	□ H07RN-F	□ 3G2.5mm ²	1600W	3200W	56°±5°	NA		11 KGS
125V/60HZ	□ 80+4.5FT	□ SJT	□ 14AWG/3C	1000W	1625W	NA	13A		9.6 KGS
	□ 75+4.5FT	□ SJTW	□ 12AWG/3C	1000W	1625W	NA	13A		8.2 KGS
	□ 65+4.5FT	□ SJTOW	□ 12AWG/3C	1000W	1875W	NA	15A	7.7 KGS	

ZD250

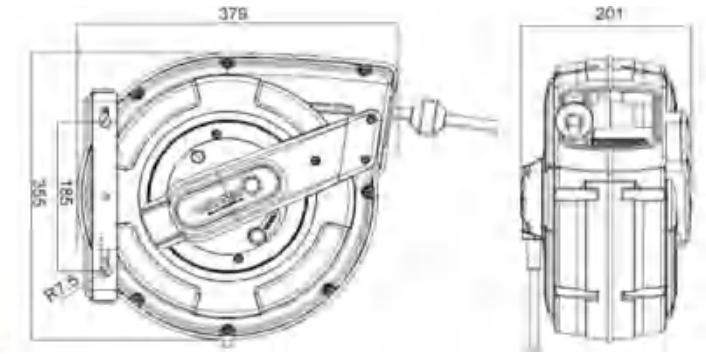

Retractable Cable Lay-out Function



Easy Repair System



IP44 Water Proof



3P+N+ CEE Connector

VOLTAGE	LENGTH	WIRE SPEC.	WIRE DIAMETER	Wound	Unwound	TEMP. PROTECT	CURRENT PROTECT	MASTER CARTON	WEIGHT
230V/50HZ	□ 25+1M	□ H05VV-F	□ 3G1.5mm ²	1000W	2300W	56°±5°	NA	L: 39.5cm W:37.5cm H:21.5cm (1 PC)	8.5 KGS
	□ 20+1M	□ H07RN-F	□ 3G2.5mm ²	1600W	3200W	56°±5°	NA		11 KGS
125V/60HZ	□ 65+4.5FT	□ SJT	□ 12AWG/3C	1000W	1875W	NA	15A		8.5 KGS
	□ 80+4.5FT	□ SJTW	□ 14AWG/3C	1000W	1625W	NA	13A		8.5 KGS
	□ 80+4.5FT	□ SJTOW	□ 16AWG/3C	1000W	1250W	NA	10A	8.5 KGS	

ZD70J



- Reliable Grounding Reel Suited for Various Electrical Applications
- Safe Method of Grounding Electrical Energy Surplus
- Shock-resistant Plastic External Case with Heavy-Duty Clip

VOLTAGE	LENGTH	WIRE SPEC.	WIRE DIAMETER	NUMBER OF CONDUCTORS	TEMP. PROTECT	CURRENT PROTECT	MASTER CARTON	WEIGHT
230V/50HZ	7+1M	PVC	10mm ²	1	NA	NA	L: 58.5cm W:24.5cm H:31.5cm (4 PCS)	2.6 KGS

ZD150J



- Reliable Grounding Reel Suited for Various Electrical Applications
- Safe Method of Grounding Electrical Energy Surplus
- Shock-resistant Plastic External Case with Heavy-Duty Clip

VOLTAGE	LENGTH	WIRE SPEC.	WIRE DIAMETER	NUMBER OF CONDUCTORS	TEMP. PROTECT	CURRENT PROTECT	MASTER CARTON	WEIGHT
230V/50HZ	16+1M	PVC	10mm ²	1	NA	NA	L: 36.0cm W:31.5cm H:33.5cm (2 PCS)	5.3 KGS

ZX-ACX30



- Bright COB LEDs with 35,000 Hour Life
- Top Hook for Hands-Free Lighting

VOLTAGE	LENGTH	WIRE SPEC.	WIRE DIAMETER	MIN POWER	LUMEN	TEMP. PROTECT	MASTER CARTON	WEIGHT
230V/50HZ	□ 10+1M	□ H05RN-F □ H07RN-F	2G1.0mm ²	3W	300LM	56°±5°	58.5x24.5x31.5cm (4 PCS)	2.3 KGS
125V/60HZ	□ 33+4.5FT	□ SJT □ SJTW □ SJTOW	18AWG/2C	3W	300LM	NA		2.3 KGS

ZX-ACX60



- Bright SMD LEDs with 35,000 Hour Life
- Top Hook for Hands-Free Lighting
- Soft Grip on All Body of Light

VOLTAGE	LENGTH	WIRE SPEC.	WIRE DIAMETER	MIN POWER	LUMEN	TEMP. PROTECT	MASTER CARTON	WEIGHT
230V/50HZ	□ 15+1M	□ H05RN-F □ H07RN-F	2G1.0mm ²	6W	600LM	56°±5°	36x31.5x33.5cm (2 PCS)	4.5 KGS
125V/60HZ	□ 50+4.5FT	□ SJT □ SJTW □ SJTOW	18AWG/2C	10W	1000LM	NA		4.5 KGS



ZQ70



ZQ150



ZQ170



ZQ200A



ZQ200



Retractable Extension Air Hose Reels

Product Description

- Heavy duty industrial hose reel with spring load
- High quality engineer PP housing
- Wall bracket 180 degree swivel
- Pull the hose and stop any location as you wanted, each stop was around 50cm

Optional Connector

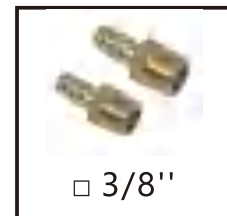
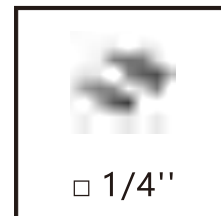

Optional Quick Connector



Certificates (All model)



ZQ70

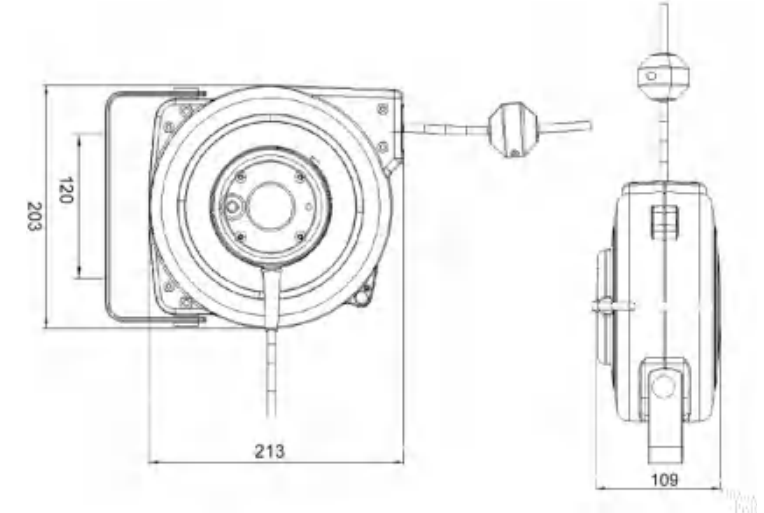

LENGTH	TUBE MATERIAL	DIA OF TUBE	WORKING PRESSURE	MAX PRESSURE	MASTER CARTON	WEIGHT
7+1M	<input type="checkbox"/> PU MESH	6.5x10mm	15 Bar	45 Bar	58.5x24.5x31.5cm (4 PCS)	2.5 KGS
	<input type="checkbox"/> PVC MESH		15 Bar	45 Bar		2.4 KGS
	<input type="checkbox"/> PU		10 Bar	30 Bar		2.4 KGS

ZQ150

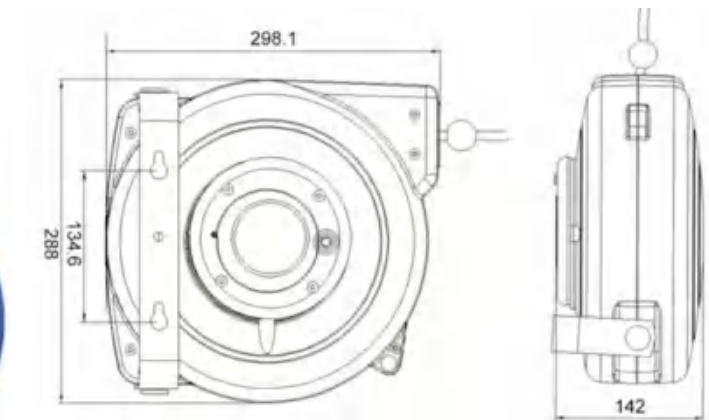

LENGTH	TUBE MATERIAL	DIA OF TUBE	WORKING PRESSURE	MAX PRESSURE	MASTER CARTON	WEIGHT
<input type="checkbox"/> 15+1M	<input type="checkbox"/> PU MESH	6.5x10mm	15 Bar	45 Bar	36x31.5x33.5cm (2 PCS)	3.7 KGS
	<input type="checkbox"/> PVC MESH		15 Bar	45 Bar		3.7 KGS
	<input type="checkbox"/> PU		10 Bar	30 Bar		3.7 KGS
<input type="checkbox"/> 10+1M	<input type="checkbox"/> PU MESH	8x12mm	15 Bar	45 Bar		4.0 KGS
	<input type="checkbox"/> PVC MESH		15 Bar	45 Bar		4.0 KGS
	<input type="checkbox"/> PU		10 Bar	30 Bar		4.0 KGS

ZQ170

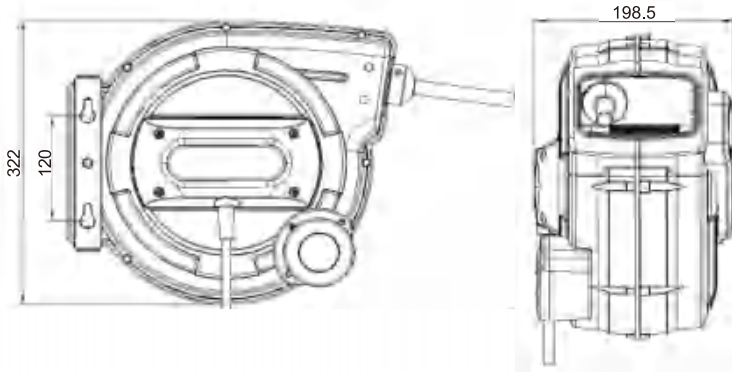

- Retractable cable lay-out function
- Slow-down device optional

LENGTH	TUBE MATERIAL	DIA OF TUBE	WORKING PRESSURE	MAX PRESSURE	MASTER CARTON	WEIGHT
□ 18+1M	□ PU MESH	8x12mm	15 Bar	45 Bar	37.5x34x21.5cm (1 PC)	5.3 KGS
	□ PVC MESH		15 Bar	45 Bar		5.3 KGS
□ 10+1M	□ PU MESH	10x14mm	15 Bar	45 Bar		5.3 KGS
	□ PVC MESH		15 Bar	45 Bar		5.3 KGS
□ 33+4.5FT	□ Hybrid Polymer	3/8"	20 Bar	60 Bar		5.3 KGS

ZQ200A

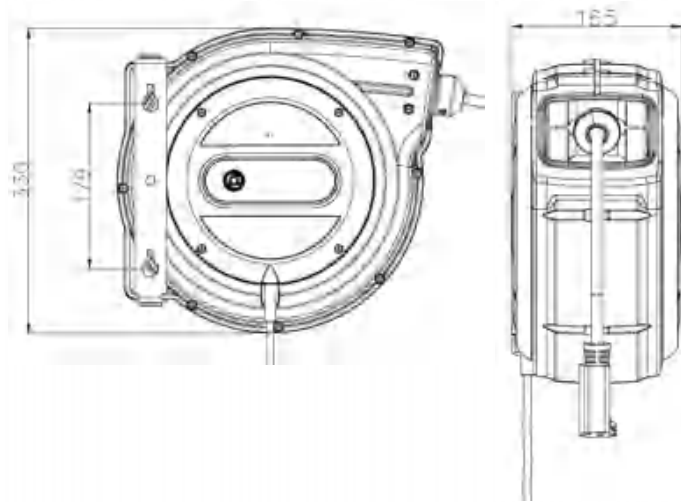

LENGTH	TUBE MATERIAL	DIA OF TUBE	WORKING PRESSURE	MAX PRESSURE	MASTER CARTON	WEIGHT
□ 20+1M	□ PU MESH	8x12mm	15 Bar	45 Bar	39x18x35.3cm (1PCS)	5.5 KGS
	□ PVC MESH		15 Bar	45 Bar		5.5 KGS
	□ PU		10 Bar	30 Bar		5.3 KGS
□ 33+4.5FT	□ Hybrid Polymer	3/8"	20 Bar	60 Bar		6.3 KGS

ZQ200

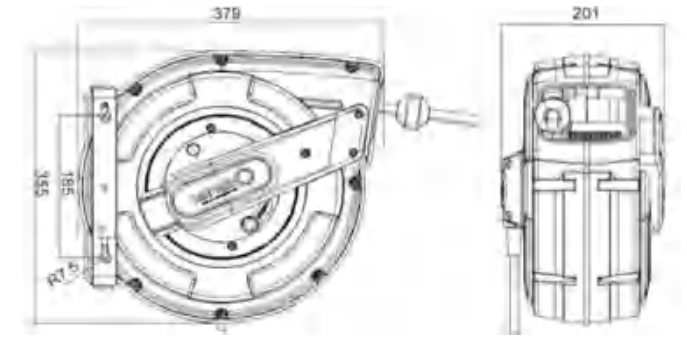

- Retractable cable lay-out function
- Easy replacement design

LENGTH	TUBE MATERIAL	DIA OF TUBE	WORKING PRESSURE	MAX PRESSURE	MASTER CARTON	WEIGHT
□ 20+1M	□ PU MESH	8x12mm	15 Bar	45 Bar	39.5x37.1x21.5cm (1 PC)	6.3 KGS
	□ PVC MESH		15 Bar	45 Bar		6.0 KGS
□ 15+1M	□ PU MESH	□ 10x14mm □ 12x16mm	15 Bar	45 Bar		5.3 KGS
	□ PVC MESH		15 Bar	45 Bar		5.3 KGS
□ 50+4.5FT	□ Hybrid Polymer	3/8"	20 Bar	60 Bar		5.3 KGS

ZQ180-TW

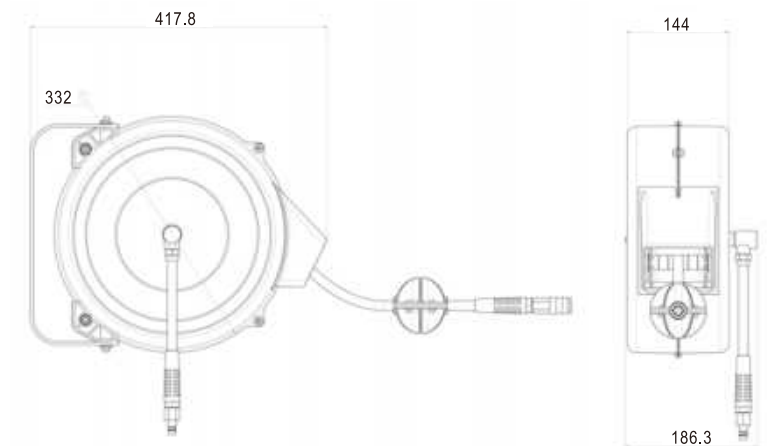

- Steel Casting Hose Reel

LENGTH	TUBE MATERIAL	DIA OF TUBE	WORKING PRESSURE	MAX PRESSURE	MASTER CARTON	WEIGHT
18+1M	PU MESH	9.5x13mm	15 Bar	45 Bar	41x36.5x41 cm (2PCS)	7.2 KGS

ZD5001,ZD5002,ZD5003



Technical Data

- AC230-50/60Hz
- Over-heat protector
- The whole cable reel is plastic
- Reel size: Dia.280MM or 310MM
- 3 or 4 individual outlet socket
- Cable standard: H07RN-F,H05RR-F,H05VV-F
- Protection Grade:IP44

MODEL NO.	VOLTAGE	MINI POWER	MAX POWER	OUTER CASE MATERIAL	DIA.OF WIRE	SPEC.OF WIRE	INPUT LENGTH	OUTPUT LENGTH	TEMP. PROTECTION	CURRENT PROTECTION	WEIGHT
ZD5001	230V-50Hz	1000W	3600W	PP	1.5mm ²	H05RR-F	NA	25M	56°±5°	NA	5.8kg
ZD5001	230V-50Hz	1000W	3600W	PP	1.5mm ²	H05RR-F	NA	50M	56°±5°	NA	8.2kg
ZD5001	230V-50Hz	1000W	3600W	PP	1.5mm ²	H07RN-F	NA	25M	56°±5°	NA	7.2kg
ZD5001	230V-50Hz	1000W	3600W	PP	1.5mm ²	H07RN-F	NA	30M	56°±5°	NA	6.5kg
ZD5001	230V-50Hz	1000W	3600W	PP	1.5mm ²	H07RN-F	NA	40M	56°±5°	NA	10kg
ZD5001	230V-50Hz	1000W	3600W	PP	2.5mm ²	H07RN-F	NA	25M	56°±5°	NA	8.2kg
ZD5002	230V-50Hz	1000W	3600W	PP	1.5mm ²	H05RR-F	NA	25M	56°±5°	NA	6.5kg
ZD5002	230V-50Hz	1000W	3600W	PP	1.5mm ²	H05RR-F	NA	50M	56°±5°	NA	9kg
ZD5002	230V-50Hz	1000W	3600W	PP	1.5mm ²	H07RN-F	NA	25M	56°±5°	NA	7.2kg
ZD5002	230V-50Hz	1000W	3600W	PP	1.5mm ²	H07RN-F	NA	40M	56°±5°	NA	10kg
ZD5002	230V-50Hz	1000W	3600W	PP	2.5mm ²	H07RN-F	NA	25M	56°±5°	NA	8.5kg
ZD5003	230V-50Hz	1000W	3600W	PP	1.5mm ²	H07RN-F	NA	25M	56°±5°	NA	10kg
ZD5003	230V-50Hz	1000W	3600W	PP	2.5mm ²	H07RN-F	NA	25M	56°±5°	NA	11kg

ZS150-B



Technical Data

- Heavy duty industrial hose reel with spring load.
- High quality engineer PP housing
- Pull the hose and stop any location as you wanted, each stop was around 50cm
- Wall bracket 180 degree swivel

MODEL NO.	OUTER CASE MATERIAL	TUBE MATERIAL	DIA.OF TUBE	WORKING PRESSURE	MAX. PRESSURE	INPUT LENGTH	OUTPUT LENGTH	WEIGHT
ZS150-B	PP	PVC	20X5MM	5Bar	10Bar	1M	15M	4.7kg

ZJ70



- Safe and Easy Installation for Dangerous Working Areas
- White-red and Yellow-black or Customized Tapes
- UV Resistant Barrier Tape for Out Door Use

TAPE LENGTH	TAPE WIDTH	SIZE OF REEL	MASTER CARTON	WEIGHT
9M	50 MM	21x20x10.9 CM	58.5x31.5x33.5 CM (4 PCS)	1.7 KGS

ZJ150



- Safe and Easy Installation for Dangerous Working
- White-red and Yellow-black or Customized Tapes
- UV Resistant Barrier Tape for Out Door Use

TAPE LENGTH	TAPE WIDTH	SIZE OF REEL	MASTER CARTON	WEIGHT
20M	50 MM	30x29x14 CM	36x31.5x33.5 CM (2 PCS)	3.7 KGS

ZXL-1111



Technical Data

- Slim housing for wide use with COB or SMD lighting
- Soft grip on all body
- Main housing material ABS and soft grip
- 3 step(main light on/off, top light on/off and power off) switch in one
- With four strong magnet in the back
- Working time 3-4 hour and charger time 3-4 hour
- With steel hook and included the charger.
- Customer Logo can made on the housing

INPUT SPEC	COLOR	BRIGHTNESS	LED TYPE	WORKING TIME	CHARGING TIME	WATER PROOF	WEIGHT
3.7V Li-ion 2000mAh	6400K	200LM	COB SMD	3-4h	3-4h	IP20	170g

ZXL-8211



Technical Data

- COB work lighting
- TPR handle
- Size: 155x40x20mm
- Weight: 132g
- Head light was 60lms
- Main lighting 150lms
- Charger time 2.5h
- Work time 3h
- Battery: 3.7V, 1200mAh
- On/off switch in the back
- Magnet in the handle
- Battery status indication

INPUT SPEC	COLOR	BRIGHTNESS	LED TYPE	WORKING TIME	CHARGING TIME	WATER PROOF
3.7V 1200mAh	6500K	60/150LM	COB	3h	2.5h	Ip64

ZXL-1141



Technical Data

- Slim housing for wide use
- H05RN-F, 2x1.0 5 meter with 300lms brightness
- 360 degree rotate metal hook in the top
- With four strong magnet in the back

INPUT SPEC	COLOR	BRIGHTNESS	LED TYPE	WORKING TIME	CHARGING TIME	WATER PROOF	WEIGHT
AC120-230V	6400K	300LM	COB SMD	NA	NA	IP20	160g

ZXL-2201



Technical Data

- COB or SMD Version
- 180 degree rotate, and magnet in the bottom
- All body ABS and soft Painting
- Charger instruction light
- Hook in the back and IP20
- Three in one switch (on/off and power adjustment)
- Working light 3-4 hours and charging time same
- Customer logo pad printing

INPUT SPEC	COLOR	BRIGHTNESS	LED TYPE	WORKING TIME	CHARGING TIME	WATER PROOF	WEIGHT
3.7V Polymer 1000mAh	6400K	55/110LM	COB SMD	3-4h	3-4h	IP20	100g



ZXL-2111



Technical Data

- COB or SMD Version
- 180 degree rotate, and magnet in the bottom
- All body PC and soft grip
- Charger instruction light and battery status indication
- Hook in the back and IP65
- Three in one switch (on/off and power adjustment)
- Working light 3-4 hours and charging time same
- With charger base
- Customer logo pad printing

INPUT SPEC	COLOR	BRIGHTNESS	LED TYPE	WORKING TIME	CHARGING TIME	WATER PROOF	WEIGHT
3.7V Li-ion 2200mAh	6400K	100/250LM	COB SMD	3-4h	3-4h	IP65	380g

ZXL-6211



Technical Data

- 10w handle use design flood light
- Alu. housing and rubber part around the corner
- High quality LED COB
- Charging and battery status indication
- IP65 water proof
- Easy carry handle with 180 degree rotate
- USB 5V/1A output charger included.
- OPTION :**
- Color match light ZXL-6211M
- CRI ≥ 95
- Color:4500K

INPUT SPEC	COLOR	BRIGHTNESS	LED TYPE	WORKING TIME	CHARGING TIME	WATER PROOF	WEIGHT
11.1V Li-ion 2200mAh	6000K	300/500/1000LM	COB	3-4h	3-6h	IP65	1860g



ZXL-6411



Technical Data

- 10w handle use design flood light
- Alu. housing and rubber part around the corner
- 3 step power adjustment, 500lm/1000lm/1500lm and 6500k.
- Li-ion battery 14.8V, 2600mAhx4pcs, citizen chips.
- Charging time 3-4 hours and working time 3hour@1500LM
- Constant Current.
- Wall Charger Output DC16.8V,1A .
- IP64 water proof.
- Easy carry handle with 180 degree rotate.
- Stand with magnet.

INPUT SPEC	COLOR	BRIGHTNESS	LED TYPE	WORKING TIME	CHARGING TIME	WATER PROOF	WEIGHT
14.8V Li-ion 2600mAhx4pcs	6500K	500/1000/1500LM	COB	3hour@ 1500LM	3-4h	IP64	870g

ZXL-6311



Technical Data

- 30w handle use design flood light
- Alu. housing and rubber part around the corner
- 3 step power adjustment, 500lm/1500lm/4000lm and 6500k.
- Li-ion battery 14.8V, 2600mAh x4pcs, citizen chips
- Charging time 3-4 hours and working time 3 hour @1500LM.
- Constant Current.
- Stand with magnet.
- Wall Charger Output DC16.8V ,1A.
- IP64 water proof
- Easy carry handle with 180 degree rotate

INPUT SPEC	COLOR	BRIGHTNESS	LED TYPE	WORKING TIME	CHARGING TIME	WATER PROOF	WEIGHT
14.8V Li-ion 2600mAhx4pcs	6500K	500/1500/4000LM	COB	3hour@ 1500LM	3-4h	IP64	1742g

